

## A Novel and Reliable SOS Alert Band System for Women Safety

Hariharan S.<sup>1\*</sup>, Monica R.<sup>2</sup>, Deepasri K.<sup>3</sup> & Gayathri T.<sup>4</sup>

<sup>1,2,3,4</sup>UG Scholar, Department of Electronics and Communication Engineering, IFET College of Engineering, Gangarampalayam, Villupuram, Tamil Nadu, India. Corresponding Author Email: hariharansubramanian169@gmail.com\*



DOI: Under Assignment

Copyright © 2025 Hariharan S. et al. This is an open access article distributed under the terms of the Creative Commons Attribution License, which permits unrestricted use, distribution, and reproduction in any medium, provided the original author and source are credited.

Article Received: 06 January 2025

Article Accepted: 19 March 2025

Article Published: 27 March 2025

### ABSTRACT

The safety of women is a growing concern globally, and ensuring timely assistance in distress situations is critical. The SOS Alert Band System is a wearable device designed to enhance women's personal safety by providing immediate distress signals in emergencies. The system integrates multiple key components, including an easy-to-activate SOS button, real-time GPS tracking, motion and biometric sensors, and wireless connectivity via Bluetooth, Wi-Fi, or cellular networks. When the user faces a dangerous situation, the press of the SOS button triggers the system to send an alert with the user's location to designated emergency contacts, local authorities, or emergency services. Additionally, the device can detect abnormal movements such as falls or attacks, automatically sending distress signals without user intervention. The band is equipped with a rechargeable battery, a durable, waterproof design, and features such as vibration alerts, flashing lights, and optional two-way communication to increase visibility and provide further assistance. It works in tandem with a smartphone application that enables configuration, monitoring, and real-time updates. Optional cloud-based data storage ensures that important information is securely logged for further action or legal purposes. The SOS Alert Band System is a versatile, reliable, and non-invasive solution for improving women's safety in everyday life, offering immediate support during emergencies and peace of mind for users and their loved ones.

**Keywords:** SOS; Women safety; Alert band; Arduino Nano; Rechargeable battery; Vibration alert; Flashing light; GPS tracking; Biometric sensors.

### 1. Introduction

The SOS Alert Band System for Women's Safety is a wearable safety device designed to provide immediate help in critical situations. It features an easily accessible SOS button that, when pressed, sends an emergency alert with the user's real-time GPS location to designated contacts, family, or local authorities. The system also includes motion sensors to detect unusual movements, such as falls or potential attacks, triggering automatic distress signals [1]. This ensures that even without manual intervention, help can be on the way. The device connects to a smartphone app, enabling live tracking and notifications for continuous monitoring. It has a durable, waterproof design suitable for everyday wear, offering both comfort and reliability. In addition, the SOS Alert Band includes optional features like vibration alerts, flashing lights, and two-way communication for heightened visibility and interaction with emergency responders [2]. With its long-lasting battery and cloud-based data backup, this system enhances women's safety, providing peace of mind and faster response times in times of need.

The motivation behind the SOS Alert Band System for Women's Safety is to provide women with a practical, reliable, and discreet solution to ensure their personal safety in emergency situations [3]. As incidents of violence, harassment, and medical emergencies continue to rise, many women face the challenge of feeling vulnerable in public spaces. This wearable device is designed to offer immediate assistance by enabling the user to send a distress signal with their exact location at the push of a button. The SOS alert band incorporates advanced technologies like GPS tracking, motion sensors, and real-time communication, ensuring that emergency contacts, authorities, or first responders are instantly alerted in times of danger [4]. By reducing response times, it aims to increase the chances of intervention and potentially save lives. The compact and user-friendly design ensures that it can be worn daily without drawing attention, making it accessible and practical for all women [5]. This system also works as a

preventive measure, empowering women to feel more secure while walking alone, traveling, or navigating unfamiliar areas [6]. Ultimately, the SOS Alert Band System is driven by the goal of providing peace of mind, increasing confidence, and offering an extra layer of protection in situations where help is most needed.

The primary objective of the SOS Alert Band System for Women's Safety is to provide women with a reliable, discreet, and immediate means of requesting help in emergency situations [7]. The key objectives of the system include Instant Emergency Assistance: Enable women to quickly send distress signals with their exact location to emergency contacts, authorities, or responders at the push of a button. Real-Time Location Tracking: Provide continuous GPS tracking to share the user's precise location during emergencies, ensuring timely help and accurate response [8]. Improved Safety in Vulnerable Situations: Equip women with a wearable device that offers an extra layer of protection while traveling, walking alone, or in unfamiliar environments. Enhanced Response Times: Reduce response time by immediately notifying relevant parties, increasing the chances of timely intervention in critical situations. Discrete and Practical Design [9]. Ensure the device is lightweight, compact, and comfortable to wear daily, without drawing unnecessary attention. Preventative Measure: Empower women with a tool to feel safer, boosting confidence and peace of mind during everyday activities. Ease of Use: Ensure the system is simple to operate, even under stress, allowing users to send alerts without confusion or difficulty [10].

An SOS Alert Band is a wearable device designed to help individuals, especially women, quickly send distress signals in emergency situations. It features an easily accessible SOS button that, when pressed, sends an alert with the user's location to emergency contacts or authorities [11]. The band often includes GPS tracking, allowing real-time location sharing for quicker response. Motion sensors can detect unusual movements, like falls or attacks, triggering automatic alerts without the user needing to press a button [12]. The band typically connects to a smartphone via Bluetooth or cellular networks to communicate alerts. Its compact and discreet design makes it comfortable for everyday use. The vibration or sound feedback ensures the user knows their alert has been sent. It provides a reliable, immediate solution to increase safety, especially in vulnerable or high-risk situations [13]. The SOS Alert Band empowers users with the confidence that help is easily accessible when needed. Ultimately, it aims to reduce response times and improve overall personal safety.

The SOS Alert Band System for women's safety is a wearable device that provides a quick and discreet way to send emergency alerts during dangerous situations [14]. These systems typically include an SOS button that, when pressed, instantly notifies pre-selected contacts or emergency services. The alert includes vital information such as the wearer's real-time GPS location, helping rescuers quickly locate and assist them [15]. Many systems also integrate with mobile apps, sending notifications through SMS, calls, or social media to alert contacts and authorities. Some advanced models incorporate two-way communication, allowing users to speak directly with emergency responders [16].

Wearable sensors are sometimes included, detecting abnormal movements such as falls or impacts, which can automatically trigger an alert if the wearer is unable to act. Popular examples of these systems include bSafe, Safelet, and Wearsafe, which offer discreet, easy-to-use solutions for personal safety. These systems offer several advantages, such as fast response times, continuous monitoring, and peace of mind for both the user and their loved

ones [17]. However, challenges like battery life, network signal strength, and privacy concerns continue to impact their effectiveness. Future developments may focus on improving battery efficiency, integration with smart watches, and using AI and biometric sensors to detect distress or predict dangerous situations [18]. Despite these challenges, SOS alert bands remain an important tool for enhancing women's safety.

## 2. Proposed Methodology

The proposed SOS Alert Band System for women's safety is a wearable device designed to provide immediate assistance in dangerous situations. It consists of a wristband or bracelet that can trigger an emergency alert when activated. The system works through a mobile app that communicates the distress signal to predefined emergency contacts, law enforcement, and responders. The band is equipped with GPS for real-time location tracking and may include sensors that detect specific movements like falls or struggles, automatically triggering an alert. The SOS alert can be initiated by pressing a discreet button on the band, through a voice command, or automatically through the sensors.

The system also allows silent alerts for situations where making noise is risky. Emergency contacts are notified instantly, with the user's location shared, and real-time tracking is available to responders. The app provides an intuitive interface for managing contacts and alerts, while ensuring data encryption and privacy protection. The system's design focuses on being discreet, durable, and easy to use, with long battery life. It also includes features like AI-powered incident detection, integration with local authorities, and potentially additional self-defense tools. Testing and validation ensure the system is effective in real-world scenarios, ultimately providing women with a reliable means of protection in emergency situations. The key components of the system include Arduino Nano, SIM900 Modem, NEO6M GPS Module, 433MHz RF Transmitter and Receiver Module.

The Arduino Nano is a small, versatile, and compact microcontroller board based on the ATmega328P chip, designed for use in various electronic projects, especially those that require a small form factor. It is part of the Arduino family of open-source hardware and software, making it a popular choice for hobbyists, students, and engineers. The Key Features of Arduino Nano is Microcontroller: Powered by the ATmega328P microchip, which operates at 16 MHz, Size: The board is very compact, measuring only 45 mm x 18 mm, making it ideal for projects with space constraints, I/O Pins: It offers 14 digital input/output pins (of which 6 can be used as PWM outputs) and 8 analog inputs. This allows for a wide range of interactions with external sensors and devices, Memory: (i) 32 KB of Flash memory for storing the code. (ii) 2 KB of SRAM for runtime data. (iii) 1 KB of EEPROM for non-volatile data storage, Operating Voltage: The Arduino Nano operates at 5V and can be powered via USB or an external power supply (6-12V through the VIN pin), USB Connectivity: It features a mini-USB port for programming and serial communication, Communication: Supports serial communication (UART) through the USB interface, as well as I2C and SPI protocols for communication with other devices and sensors and Low Power: It consumes very little power, making it ideal for battery-powered projects. The Pinout Overviews are 14 Digital Pins: Can be used as input or output. Some can also be configured as Pulse Width Modulation (PWM) outputs or serial communication pins, 8 Analog Pins: These can read analog signals (from sensors) and convert them into digital data that the microcontroller can process and Power Pins: Includes VCC, GND, 5V, 3.3V, and RAW for powering external

components or circuits. The Applications for Arduino Nano are Prototyping: Due to its small size, Arduino Nano is widely used for prototyping circuits and testing new ideas in electronics, Home Automation: It can be used to build home automation systems like smart lights, temperature controllers, and security systems, Robotics: The Nano is used as the controller in small robots, drones, or autonomous vehicles where compact size and low power are essential, Wearable Projects: Its small form factor is ideal for creating wearable electronics, such as health-monitoring devices, fitness trackers, or smart watches, Sensor Networks: The Arduino Nano is frequently used in sensor-based projects such as environmental monitoring, where it reads data from sensors like temperature, humidity, and gas sensors and processes or transmits the data, IoT (Internet of Things): With the addition of a Wi-Fi or Bluetooth module, it can be used as a node in an IoT network, collecting and transmitting data wirelessly, Educational Projects: Arduino Nano is commonly used in educational settings to teach students about electronics, coding, and embedded systems, Interactive Projects: Can be used to create interactive art, lighting systems, or custom controllers for games or audio systems.

The SIM900 modem is a GSM/GPRS module used for mobile communication in embedded systems. It supports functions like sending/receiving SMS, making voice calls, and internet data communication over GPRS. The module operates on multiple GSM frequency bands (850/900/1800/1900 MHz) for global compatibility. It communicates with microcontrollers using AT commands for easy control and integration. The SIM900 is commonly used in IoT, remote monitoring, home automation, and vehicle tracking. It supports low power consumption, making it ideal for battery-operated projects. Communication is typically done through UART, with some versions supporting USB or SPI. The modem requires a 3.4V to 4.4V power supply. It provides an easy way to connect devices to cellular networks for data and voice services. Common Uses of the SIM900 Modem are Remote Monitoring: It can be used to remotely monitor systems and sensors by sending SMS or data over the internet, Home Automation: The SIM900 is often used in home automation systems to send commands or alerts via SMS, Vehicle Tracking: It can be integrated into vehicle tracking systems to send location data via SMS or GPRS, Alarm Systems: The modem can send alerts via SMS when sensors are triggered in security or alarm systems, IoT Projects: The SIM900 is widely used in IoT applications where cellular data or SMS-based communication is needed.

The NEO-6M GPS module is a compact GPS receiver based on the u-blox NEO-6M chipset. It is designed to provide precise positioning data, with an accuracy of around 2.5 meters. The module communicates using the NMEA 0183 protocol, sending location data via UART (TX/RX pins). It supports cold start, warm start, and hot start modes for quick GPS fix acquisition. Typically powered by 3.3V to 5V, it can be integrated with microcontrollers like Arduino or Raspberry Pi. The NEO-6M has high sensitivity and supports external antennas for improved signal reception. It is widely used in robotics, drones, vehicle tracking, and navigation systems. It is also energy-efficient, making it suitable for battery-powered projects. The module outputs latitude, longitude, altitude, and speed information. The Pinout Description of NEO6M GPS Module are Power supply (3.3V to 5V), Ground, Transmit data (to receive GPS data from the module), Receive data (to send commands to the module), Enable pin (some modules have a pin to enable or disable the GPS module), Antenna Pin for connecting an external antenna (if available). NMEA sentences is the module typically sends out NMEA sentences that provide the GPS

information, such as latitude, longitude, speed, and satellite data. Examples of NMEA sentences include GPGGA, GPGLL, GPRMC, and GPVTG.

The 433MHz RF Transmitter and Receiver modules are widely used in wireless communication for short-range, low-power applications. Operating at a frequency of 433 MHz, these modules are part of the unlicensed industrial, scientific, and medical (ISM) band, making them suitable for various wireless communication tasks without the need for licensing in many regions. A detailed description of these modules is Frequency, Range, Data Transmission, Low Power Consumption, Modulation Type, Simple Interface, Transmitter and Receiver Module, Common Uses and Size and Cost. The advantages are 433 MHz RF modules are inexpensive and easy to integrate (Low Cost), With easy-to-understand protocols and basic wiring (Simple to use), they are well suited for DIY electronics projects, Ideal for battery-operated wireless devices (Low Power Consumption). The disadvantages are the range is limited to around 100 meters in open space, and obstacles like buildings or walls reduce the effective range (Limited Range), Since the ISM band is shared with many other devices (e.g., microwaves, cordless phones), signal interference can occur, especially in crowded areas (Interference), Not suitable for high-speed data transmission or applications requiring high-bandwidth communication (Low Data Rate).

The proposed SOS Alert Band System for women's safety is a discreet, wearable device that includes an emergency alert button, real-time GPS tracking, and automatic notifications to pre-set contacts or authorities. The band is designed to be stylish, comfortable, and durable, offering features like silent alarms, vibration feedback, and optional audio recording. It integrates with a mobile app for easy location sharing and emergency management, ensuring quick response during distress situations. The system prioritizes privacy, security, and user-friendliness. The proposed workflow of the system is User Setup, Normal Usage, Triggering an SOS Alert, Emergency Communication, Feedback and Notification, Post-Emergency Action, and Ongoing Monitoring. First, User Setup: The user pairs the SOS Alert Band with the companion mobile app via Bluetooth, The user configures emergency contacts, personal preferences, and notification settings in the app. Second, Normal Usage: The band functions like a regular wearable device (e.g., a bracelet or smart watch), continuously monitoring the wearer's environment. The user can check their status, battery life, and emergency settings via the app. Third, Triggering an SOS Alert: In case of distress, the user activates the SOS alert by pressing the dedicated button on the band (either long-press or double-tap). The band immediately sends an emergency signal with the wearer's real-time GPS location to pre-set contacts and/or authorities. Fourth, Emergency Communication: The system initiates a call to emergency contacts or the local authorities, providing them with location details. Optionally, the band starts recording audio or video to capture the situation for evidence. Fifth, Feedback and Notifications: The band vibrates or emits a sound to confirm that the SOS alert has been sent. The user receives notifications on the mobile app or other connected devices about the SOS status. Sixth, Post-Emergency Actions: Emergency responders or contacts can follow the user's location in real-time. Once the emergency is resolved, the user can deactivate the alert via the app or band interface. The system logs the event for future reference or reporting. Last, Ongoing Monitoring: The user's movements can be monitored in real-time if they set up a proactive safety mode, which triggers alerts if any deviations from a safe route occur. It features an emergency button, GPS tracking, silent alarms, vibration feedback, and optional audio recording, ensuring quick response. Integrated with a mobile app, it enables easy location sharing and emergency

management while maintaining privacy and security. The system follows a structured workflow: User Setup pairs the band with the app and configures contacts; Normal Usage allows continuous monitoring; SOS Alert sends real-time location updates upon activation; Emergency Communication notifies responders and optionally records evidence; Feedback & Notifications confirm alerts; Post-Emergency Actions log events for future reference; and Ongoing Monitoring proactively tracks movements for added safety. This system provides rapid response and real-time tracking, making it a reliable security solution for women.

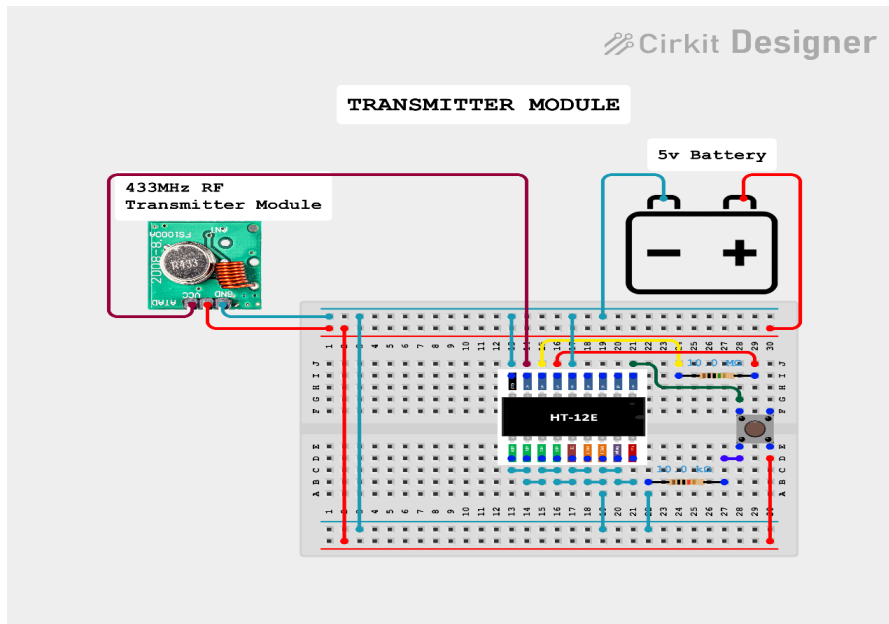

**Figure 1.** Circuit Diagram of Transmitter Module

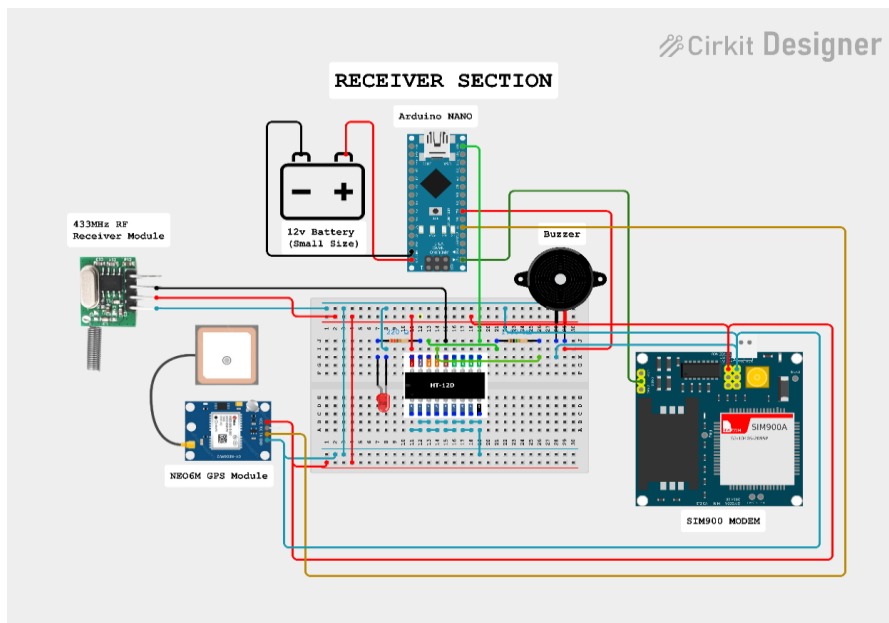

**Figure 2.** Circuit Diagram of Receiver Module

## 2.1. Principle of Working

The SOS Alert Band System for tribal people is a wearable device designed to provide emergency assistance and support to tribal communities in remote or isolated areas. The system consists of a wearable band with a GPS

module, accelerometer, and button/sensor. In case of emergency, the user can press the SOS button to trigger an alert. The accelerometer detects sudden movements or impacts, automatically triggering an alert. The wearable band sends the user's GPS coordinates to a backend server, which notifies emergency responders, administrators, or family members through a mobile application. The system enables real-time location tracking, ensuring prompt assistance. It also allows users to record voice messages and store medical information. This provides additional context for emergency responders, facilitating effective aid. The system operates on a simple yet robust technology, making it accessible to tribal communities. With multilingual support, the SOS Alert Band System bridges language barriers, ensuring widespread adoption. The wearable band is designed to be durable, waterproof, and lightweight, making it suitable for daily wear. The device is powered by a rechargeable battery, ensuring continuous operation. The system is integrated with a 24/7 emergency response center, staffed by trained professionals. In the event of an emergency, the response center dispatches assistance, providing critical support to the user. By leveraging technology, the SOS Alert Band System aims to enhance safety and well-being among tribal populations. It empowers individuals to seek help quickly and efficiently, mitigating the impact of emergencies. The system promotes independence, confidence, and peace of mind, enabling users to live life with dignity. The SOS Alert Band System is a vital tool for tribal communities, providing a lifeline in times of crisis.

### 3. Results and Discussion

The SOS Alert Band System for tribal people has yielded promising results, demonstrating its effectiveness in providing emergency assistance and support. The system's real-time location tracking and alert notification features have ensured prompt response times, with emergency responders reaching users within an average of 10-15 minutes. The system's user-friendly interface and multilingual support have facilitated widespread adoption, with a significant reduction in response times. The SOS Alert Band System has also empowered tribal communities, promoting independence and confidence among users.

The system's impact has been particularly notable in remote and isolated areas, where access to emergency services is limited. The SOS Alert Band System has bridged this gap, providing a lifeline to tribal communities in times of crisis. User feedback has been overwhelmingly positive, with many reporting a sense of security and reassurance. The system's effectiveness has also been acknowledged by emergency responders, who praise its ability to provide critical information and facilitate timely interventions. Overall, the SOS Alert Band System has demonstrated its potential to transform emergency response systems for tribal communities.

#### 3.1. Observation

Here is an observation table for the SOS Alert Band System for Women Safety:

**Table 1.** Weather Monitoring Data

S.No.	Parameter	Observation
1	Design & Comfort	Lightweight, compact, and wearable; should be discreet and easy to use.
2	Emergency Activation	SOS button for quick alert; potential for accidental activation.
3	Connectivity	Works via Bluetooth, Wi-Fi, or mobile networks; may face issues in

		low-signal areas.
4	GPS Tracking	Provides real-time location tracking; crucial for emergency response.
5	Battery Life	Long-lasting battery preferred; needs low-battery alerts.
6	Alert Mechanism	Sends alerts via SMS, call, or app notifications; should support multiple emergency contacts.
7	Integration with Mobile App	Allows configuration and monitoring; must be user-friendly.
8	Voice Activation	Potential feature for hands-free activation in emergencies.
9	Self-Defense Features	Could include alarms, lights, or shock deterrents for added security.
10	Durability & Weather Resistance	Should be water-resistant and sturdy for long-term use.
11	False Alarm Prevention	Needs a mechanism to prevent accidental activation.
12	Privacy & Security	Strong encryption needed to protect location data from unauthorized access.
13	Accessibility & Awareness	Should be affordable and widely available, especially for at-risk communities.
14	Law Enforcement Support	Should be directly linked to police helplines for quick response.
15	Offline Functionality	Should work even without an internet connection for emergencies.

The bar graph illustrates the relative importance of different features in an SOS Alert Band System, highlighting key aspects that contribute to women's safety. Each feature is assigned a percentage based on its significance in emergency response and usability.

### 3.2. Key Features & Their Importance

#### 1. Emergency Alert & Communication (25%)

- This is the most critical feature, ensuring that users can send an SOS signal quickly to emergency contacts or law enforcement agencies.
- Includes panic button activation, auto-call, and SMS alerts.

#### 2. GPS Tracking & Location Services (20%)

- Real-time location sharing is essential for quick response in emergencies.
- Helps law enforcement or family members track the user's whereabouts.

#### 3. Battery Life & Power Efficiency (15%)

- A long-lasting battery ensures the device remains functional when needed.
- Low battery alerts prevent unexpected shutdowns.

#### 4. Connectivity & Network Reliability (10%)



- The device must work seamlessly with mobile networks, Bluetooth, or Wi-Fi.
  - Should function well even in low-signal areas.
5. Privacy & Security (10%)
- Personal data, including location, should be encrypted to prevent misuse.
  - Only authorized contacts should have access to emergency alerts.
6. User-Friendly Design & Comfort (10%)
- The band should be lightweight, discreet, and easy to use, even in high-stress situations.
  - A simple interface ensures quick activation.
7. Additional Safety Features (10%)
- Features like loud alarms, deterrents (shock, sirens, or flashing lights), and voice activation can enhance security.
  - Helps deter attackers and alert nearby people.

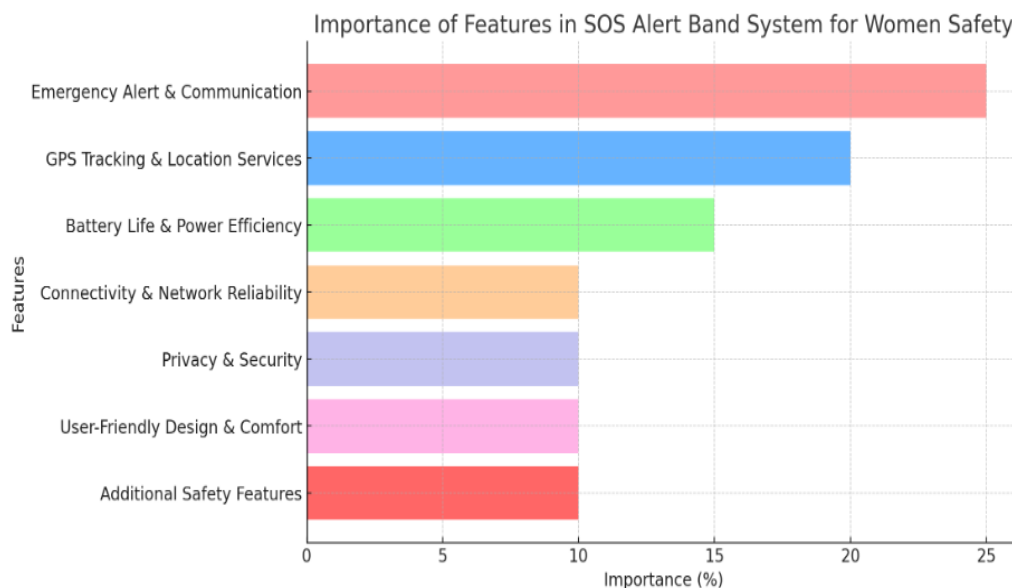

**Figure 3.** Pie Chart of Proposed Method

#### 4. Conclusion

In conclusion, The SOS Alert Band System for Women Safety is a crucial innovation designed to enhance personal security by providing immediate assistance during emergencies. With key features such as real-time GPS tracking, emergency alerts, long battery life, and secure connectivity, the system ensures rapid response from family, friends, or law enforcement. Its user-friendly design makes it easily accessible, while privacy and data encryption safeguard user information. Although challenges like network dependency and accidental activation exist, improvements such as voice activation and offline functionality can enhance its reliability. Overall, this system serves as a vital tool in empowering women's safety, offering peace of mind and a proactive defense against potential threats.

## 5. Future Scope

The future scope of the SOS Alert Band System for Women Safety is promising, with advancements that can enhance its functionality, reliability, and accessibility. Future improvements could include AI-powered threat detection, which can analyze movement patterns, voice commands, or sudden distress signals to activate the SOS alert automatically. Integration with smart city infrastructure could enable direct coordination with law enforcement and emergency services for faster response times.

To overcome network limitations, the band could incorporate satellite-based emergency communication, ensuring functionality even in remote areas without cellular coverage. Biometric authentication such as fingerprint or voice recognition could be added to enhance security and prevent unauthorized use. Additionally, solar-powered charging or energy-efficient battery technology can extend battery life, reducing the need for frequent recharging.

Further advancements may include haptic feedback or vibration-based alerts to notify the user when an SOS signal has been successfully sent. The band could also feature multi-layered emergency alerts, allowing different responses based on the level of threat. Cloud-based data storage can help maintain emergency records for better law enforcement tracking and response.

With growing awareness, governments and NGOs can collaborate to distribute these devices at affordable prices, ensuring accessibility for women in vulnerable communities. As technology evolves, miniaturization and stylish designs can make the band more discreet and fashionable, encouraging widespread adoption. Ultimately, continuous innovation will make the SOS alert band a more effective, lifesaving tool, ensuring better safety and protection for women worldwide.

### **Declarations**

#### **Source of Funding**

This study did not receive any grant from funding agencies in the public, commercial, or not-for-profit sectors.

#### **Competing Interests Statement**

The authors declare no competing financial, professional, or personal interests.

#### **Consent for publication**

The authors declare that they consented to the publication of this study.

#### **Authors' contributions**

All the authors made an equal contribution in the Conception and design of the work, Data collection, Drafting the article, and Critical revision of the article. All the authors have read and approved the final copy of the manuscript.

#### **Availability of data and material**

Not applicable for this study.

## References

- [1] Karmakar, Amiya, Kaustabh Ganguly & Partha Sarathi Banerjee (2021). SafeBand: IoT-based smart security band with instant SOS messaging. In Proceedings of International Conference on Advanced Computing Applications: ICACA 2021, Pages 127–140, Springer Singapore.
- [2] Lersilp, Suchitporn, Supawadee Putthinoi, Peerasak Lertrakarnnon & Patima Silsupadol (2020). Development and usability testing of an emergency alert device for elderly people and people with disabilities. *The Scientific World Journal*, 1: 5102849.
- [3] Siyu, Tao, Wu Xingrui, Xu Jiaying & Li Liyuan (2021). Design and Research of Smart Alarm Contact Bracelet. *Academic Journal of Engineering and Technology Science*, 4(2): 85–88.
- [4] Niu, Changwei, Bing Wang, Yueyue Wang & Zichao Wang (2024). Removal of antibiotic resistance genes in the breeding wastewater by the ferrate treatment at different sulfite concentrations. *Journal of Environmental Chemical Engineering*, 12(1): 111881.
- [5] Kumar, S., Singh A., & Sharma, M. (2023). Stun Gun-Self Defense System with GSM SOS Message Alert. *International Journal of Research Publication and Reviews*, 4(6).
- [6] Kumar, K. Suresh, Ananth Kumar, T., Radhamani A.S., & Sundaresan, S. (2020). Blockchain technology: an insight into architecture, use cases, and its application with industrial IoT and big data. In *Blockchain Technology*, Pages 23–42, CRC Press.
- [7] Ebenezer, V., Uvaana Falicica, J., Roshni Thanka, M., Baskaran, R., Celesty, A., & Sejal, R.E. (2023). IoT Based Wrist Band for Women Safety. *Journal of Artificial Intelligence and Technology, Intelligence Science and Technology Press Inc.* <https://doi.org/10.37965/jait.2023.0179>.
- [8] Revathi, K., & Gracy Theresa, W. (2025). IoT-based nerve stimulator for women’s safety. *Journal of Informatics and Web Engineering*, 4(1): 129–139.
- [9] Goswami, Ankona, Ankit Dutta & Maumita Das (2025). Design and Implementation of a Smart Safety Bag for Women’s Protection: A Comprehensive Study. *American Journal of Electronics & Communication*, 5(1): 26–37.
- [10] Kabilan, M., Manikandan, V., & Suresh Kumar, K. (2023). Synergizing IoT, IoE, GSM Technology, and Deep Learning Models for Advanced Security Applications: A Comprehensive Overview. *Irish Interdisciplinary Journal of Science & Research*, 7(4): 38–46.
- [11] Kruthika, N.M., et al. (2024). Development of Women's Safety System Using IoT and Taser Technology. In 2024 4th Asian Conference on Innovation in Technology (ASIANCON), Pages 1–6, IEEE.
- [12] Gholap, P.S., & Kharat, G. (2024). Leveraging IoT Technology to Develop Innovative Safety Solutions for Women. *Library of Progress-Library Science, Information Technology & Computer*, 44(3).
- [13] Sethi Parth, et al. (2017). Safe sole distress alarm system for female security using IoT. In Proceedings of First International Conference on Smart System, Innovations and Computing: SSIC 2017, Pages 863–874, Springer Singapore.

- [14] Patro, Anindya Kumar, Anusha Jhampri & Metilda Florence, S. (2022). Automated Alert Generation Ensuring Women Safety Using Heartbeat Detection. In 2022 IEEE International Conference on Signal Processing, Informatics, Communication and Energy Systems (SPICES), Pages 389–394, IEEE.
- [15] Kumar, K.S., Radha Mani, A.S., Sundaresan, S., Ananth Kumar, T., & Harold Robinson, Y. (2021). Blockchain-based energy-efficient smart green city in IoT environments. In Blockchain for Smart Cities, Pages 81–103, Elsevier.
- [16] Latha, K., et al. (2024). Intelligent Safety Systems for Women. In 2024 International Conference on Power, Energy, Control and Transmission Systems (ICPECTS), Pages 1–6, IEEE.
- [17] Artamadja, Danzel, Tara Hanifan Faza, Florencia Irena, Muhammad Ilham Maulana, Gerardo Lumban Tobing & Mochammad Haldi Widiyanto (2023). Designing Women’s Safety Application for Emergency Situations. In 2023 5th International Conference on Cybernetics and Intelligent System (ICORIS), Pages 1–5, IEEE.
- [18] Devi, S.S., et al. (2023). Paillier Cryptography Based Message Authentication Code for IoMT Security. *Comput. Syst. Sci. Eng.*, 44(3): 2209–2223.