

IOT Based Smart Home Design for Power and Security Management

T.Saravanan¹, R.Nagarajan², K.Rajesh Kumar³, R.Vishnu Prakash⁴ and R.Rajkumar⁵

¹UG Scholar, Department of Electronics and Communication Engineering, SVS College of Engineering, Coimbatore, India.

²UG Scholar, Department of Electronics and Communication Engineering, SVS College of Engineering, Coimbatore, India.

³UG Scholar, Department of Electronics and Communication Engineering, SVS College of Engineering, Coimbatore, India.

⁴UG Scholar, Department of Electronics and Communication Engineering, SVS College of Engineering, Coimbatore, India.

⁵Assistant Professor, Department of Electronics and Communication Engineering, SVS College of Engineering, Coimbatore, India.

Article Received: 12 March 2017

Article Accepted: 22 March 2017

Article Published: 25 March 2017

ABSTRACT

The Internet of Things (IOT) provides a dynamic infrastructure for the modern world, that has self-configuring capabilities based on interoperable communication where physical and virtual things has their own identity, attributes and functions which enables the communication between them, informing the user about their abnormalities along with their default functionalities. IOT devices agree that “Security” is not a word that gets associated with this category of devices, leaving consumers potentially exposed. We use Wi-Fi protocol under the standardization as IEEE802.11 for IOT based long range communication even though service is not available for emergency environment in our life cycle. In this paper we discussed about how to provide better security for home automation and saving the energy being consumed and making flexible environment to the people.

Keywords: Internet of Things (IOT), Security and Emergency.

1. INTRODUCTION

Currently, we feel many difficulties in monitoring our home. It's not safe leaving the home alone locked because of theft problem and we don't know whether all the devices in the home are switched off of not like gas, fan, water, light, door security, motor etc., When we are out somewhere and if we have forgotten to switch off some appliances we are able to control it through the concept of IOT (internet of things). Here in this project we use sensors to monitor the level and leakage of gas in home and if there is some leakage and level of gas the alert has been sent to the owner and the security guard. In this homes are able to be controlled using IOT. This project will be more helpful in homes for controlling the devices. The every updated information will inform to the owner. The Temperature sensor is used to sense the room temperature level, if the room temperature exceeds above 40degree then the Ac can be turned ON. When the house owner went outside. They will locked to go for outside, any theft person enter inside message will send to the police station to rescue team will go to the home to safe purpose .Cell broadcast service (CBS) broadcasts emergency messages to the particular determined

Users in a specific cell area via cellular networks Automatic emergency alert service (AEAS) broadcasts emergency messages via mobile broadcasting networks such as terrestrial digital multimedia broadcasting (T-DMB). However, the technologies are available only when network infrastructures including repeaters can still sustain in the emergency situations. Recently, lots of attention has been paid to internet-of-things (IoT) since IoT technologies enable a machine-to-machine (M2M) connectivity without any aid of network infrastructure. Therefore, IoT technology is considered a strong candidate for communication when network infrastructures undergo a serious damage due to natural or social disasters. However, the research trends of IoT mainly emphasize low-cost and low-power operations

rather than direct long-range communications. In this paper, a novel transceiver is proposed for long-range IoT communications. The IoT transceiver can afford to support the service coverage of network in the case of network outage. The transceiver is based on IEEE802.11 Wi-Fi protocol. The IEEE802.11 protocol guarantees low-cost and low-power operations. The Wi-Fi protocol also supports a mild-range service for low data-rate M2M communications. Therefore, the proposed IOT transceiver can rely on the IEEE802.11 protocol in order to transmit an emergency message via M2M connectivity in emergency situations such as network outages. However, the broadcast coverage for emergency messages is usually larger than the IEEE802.11 coverage. Therefore, a novel architecture is required in the transceiver in order to enlarge the service coverage of the IEEE802.11 protocol. As an emerging WLAN technology, the IEEE802.11ah standard specifies a WLAN system operating at sub 1 GHz license-exempt bands. In the standard, the sub 1 GHz license-exempt bands imply the carrier frequencies lower than 1 GHz. Especially, 900 MHz is one of the most popular carrier frequencies for the IEEE802.11. Due to the slight modification of the standard, frequency-domain (FD) channel estimation is unavailable on the preamble since it just contains pilot the level for 58 subcarriers. Therefore, time- domain (TD) least-square method (LS) is utilized on the preamble for channel estimation, which estimates the channel parameters for 64 subcarriers. Furthermore, TD-LS method effectively exploits the preamble structure for channel estimation, which leads to better estimation performance than FD channel estimation. In addition, the presented transceiver utilizes a concatenated coding approach in order to further increase the communication range, which especially satisfies the service coverage of repeaters for mobile broadcasting networks. The concatenated coder consists of inner coder and outer coder. As an inner coder, the transceiver utilizes the proposed quasi-orthogonal (QO) coder, which is similar to the QO spreader in 2.4GHz WPAN systems. As the outer coder, the

transceiver utilizes the binary convolutional coder (BCC) as specified in the 802.11ah standard. The proposed inner coder significantly contributes to lengthen the service range at the expense of data rate, which can be compensated by entire usage of 64 subcarriers.

Experimental results exhibit that the proposed transceiver gives better channel-estimation performance, better receiver performance, and longer communication range. They also show that the presented approach is very suitable for IoT communications of emergency messages in emergency environments.

2. EXISTING MODEL

In this model we have proposed an Ethernet based system that let users monitor real time switching information of the electrical devices and controlling them through an android app as well as monitoring the security of their homes in case of unwanted entry or fire. Our model uses temperature sensor and smoke sensors to check for fire at the users home, PIR motion sensors to check for the unwanted presence at their homes and also monitor and control the real time tracking and switching of all their electrical devices through an android based mobile app. The system is connected to this android app using internet connectivity for better and fast communication. The model has an option of controlling devices by either sending voice commands or by simple tap-to-toggle system, making the overall system user friendly and easy to manage.

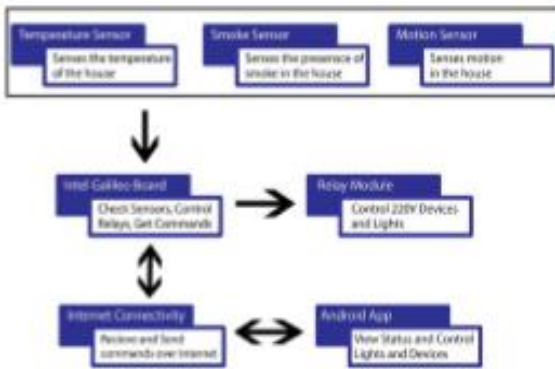

So getting in detail about the model, we have temperature sensor which works along with smoke sensor to check the presence of fire at home, PIR motion sensor to detect the human movement in the house, and relay connected devices so that they can be easily toggled by the microcontroller. The brain of our model is an Ethernet based Intel Galileo 2nd Generation Board which let our devices and sensors connected to the internet. The 2nd generation Intel Galileo board provides a single board which is based on the Intel Quark SoCX1000, a 32-bit Intel Pentium processor- class system on a chip (SoC). It is Arduino certificated and designed to be hardware, software, and pin compatible with large range of Arduino Uno R3 shields.

On the other side of our model, we have an android based mobile app that has options to track the switching time of the devices, controlling the switching of devices either

through touch mode or voice mode and also generates alerts in case of security breach or fire. The app is android based which is connected to the internet thorough either Wi-Fi or mobile dat.



It connects to the Intel Galileo based server over the internet and lets the users to monitor with the help of an internal mobile timer and toggles the switching by tap-to-touch or voice using Google API speech recognition tool. User can manually switch on or off the PIR sensor or the fire tracking system and even get alerts in case they do detect a change. The alert is sent real time to the user app and shown in the alert tab. Thus, an energy monitoring security system is being set up in the home with a user-friendly mobile app to make your home a smart and an intelligent home

3. PROPOSED MODEL

In proposed method we us the technology of IOT (internet of things) to control all appliances in homes or apartments. Here gas sensor has been used to sense weather light has been controlled or not and alert has been sent to the server and also to the security. Here we also use to send the message to the webpage based monitor page. Hear the entire database has been stored in the web server and if home appliances has been monitored through the IoT based monitor and security automatically. The Temperature of the home are measured using with sensor module to updating in IoT based webpage based monitoring system. If the temperature level is too high then we can switch ON the AC. The gas sensor is used to sense the gas leakages at home, the gas sensor senses the gases like LPG PROPANE gas, the amount of gases which has been sensed is shown as the voltage output. The output voltage of the gas sensor is converted into the digital value by using the microcontroller. The vibration sensor is used for the security purpose. The vibration sensor uses the piezo electric plates to sense whether any person comes into the room or not. Incase if any person enters into the room then the piezo electric plate will starts vibrate. At the time of vibration the type of energy is produced and the message is sent to the owner. The LDR is the Light Dependent Resistor which is used to sense the light illumination. If the Light continuously falls on the surface of LDR then the light remains turned off. Whenever the illumination is not fall on the surface of LDR then the LIGHT becomes turned ON. The main use of LDR is that when we are outside off home, we can switch ON/OFF the light as per our needs.

4. COMPONENTS USED IN PROPOSED MODEL

A. Liquid-Crystal Display (LCD)

It is a flat-panel display or other electronic visual display that uses the light-modulating properties of liquid crystals. Liquid crystals do not emit light directly. LCDs are available to display arbitrary images (as in a general-purpose computer display) or fixed images with low information content, which displays as in a digital clock. They use the same basic technology, except that arbitrary images are made up of a large number of small pixels, while other displays have larger elements.



LCDs are used in a wide range of applications including computer monitors, televisions, instrument panels, aircraft cockpit displays, and signage. They are common in consumer devices such as DVD players, gaming devices, clocks, watches, calculators, and telephones, and have replaced cathode ray tube (CRT) displays in nearly all applications. They are available in a wider range of screen sizes than CRT and plasma displays, and since they do not use phosphors, they do not suffer image burn-in. LCDs are, however, susceptible to image persistence.

B. LPG Gas Sensor

Ideal sensor for use to detect the presence of a dangerous LPG leak in your car or in a service station, storage tank environment. This unit can be easily incorporated into an alarm unit, to sound an alarm or give a visual indication of the LPG concentration. The sensor has excellent sensitivity combined with a quick response time. The sensor can also sense ISO-butane, propane. The unit will work with a simple drive circuit and offers excellent stability with long life.

This circuit is mainly designed to sense the present LPG GAS in the atmosphere. The LPG GAS (Propane) is sensed by the gas sensor. The gas sensor is the one type of transducer which produces the voltage signal depends on the gas level. Then the voltage signal is given to inverting input terminal of the comparator. The comparator is constructed by the operational amplifier LM 741. The reference voltage is given to non-inverting input terminal.

The comparator compares with normal reference signal and produces the corresponding output error signal. Then the output voltage is given to microcontroller in order to determine the presence of a dangerous LPG leak.

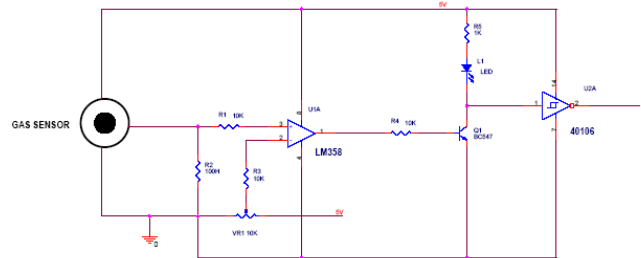

C. PIC Microcontroller: 16F877A

The microcontroller that has been used for this project is from PIC series. PIC microcontroller is the first RISC based microcontroller fabricated in CMOS (complementary metal oxide semiconductor) that uses separate bus for instruction and data allowing simultaneous access of program and data memory. The main advantage of CMOS and RISC combination is low power consumption resulting in a very small chip size with a small pin count. The main advantage of CMOS is that it has immunity to noise than other fabrication techniques.

D. PIC (16F877)

Various microcontrollers offer different kinds of memories. EEPROM, EPROM, FLASH etc. are some of the memories of which FLASH is the most recently developed. Technology that is used in pic16F877 is flash technology, so that data is retained even when the power is switched off. Easy Programming and Erasing are other features of PIC 16F877.

E. PIC Start Plus Programmer

The PIC start plus development system from microchip technology provides the product development engineer with a highly flexible low cost microcontroller design tool set for all microchip PIC micro devices. The PIC start plus development system includes PIC start plus development programmer and MPLAB ide. The PIC start plus programmer gives the product developer ability to program user software in to any of the supported microcontrollers. The PIC start plus software running under MPLAB provides for full interactive control over the programmer.

F. Relay

Relay is an electrically operated switch. Current flowing through the coil of the relay creates a magnetic field which attracts a lever and changes the switch contacts. The coil current can be on or off so relays have two switch positions and they are double throw (changeover) switches. Relays allow one circuit to switch a second circuit which can be completely separate from the first. For example a low voltage battery circuit can use a relay to switch a 230V AC mains circuit. There is no electrical connection inside the relay between the two circuits; the link is magnetic and mechanical. The coil of a relay passes a relatively large current, typically 30mA for a 12V relay, but it can be as much as 100mA for relays designed to operate from lower voltages. Most ICs (chips) cannot provide this current and a transistor is usually

used to amplify the small IC current to the larger value required for the relay coil.



JQC-3F(T73)
DC 24V 5A
AC 120V 7A
DC 3V~24V

G. Temperature Sensor

Temperature is the most-measured process variable in industrial automation. Most commonly, a temperature sensor is used to convert temperature value to an electrical value. Temperature Sensors are the key to read temperatures correctly and to control temperature in industrial applications.

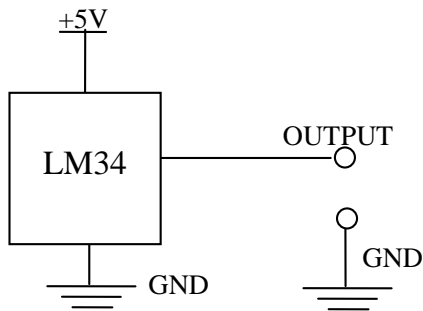

A large distinction can be made between temperature sensor types. Sensors differ a lot in properties such as contact-way, temperature range, calibrating method and sensing element. The temperature sensors contain a sensing element enclosed in housings of plastic or metal. With the help of conditioning circuits, the sensor will reflect the change of environmental temperature.

In the temperature functional module we developed, we use the LM34 series of temperature sensors. The LM34 series are precision integrated-circuit temperature sensors, whose output voltage is linearly proportional to the Fahrenheit temperature. The LM34 thus has an advantage over linear temperature sensors calibrated in degrees Kelvin, as the user is not required to subtract a large constant voltage from its output to obtain convenient Fahrenheit scaling. The LM34 does not require any external calibration or trimming to provide typical accuracies of $\pm 1.2^\circ\text{F}$ at room temperature and $\pm 11.2^\circ\text{F}$ over a full -50 to $+300^\circ\text{F}$ temperature range. The LM34 is rated to operate over a -50° to $+300^\circ\text{F}$ temperature range.

H. Vibration Sensor

Piezo electric plate is the special type of sensor which is used to sense the mechanical vibration. Piezo electric plate converts the mechanical vibration to electrical signal. The converted electrical signal is in the range of small milli-voltage signal.

Then the electrical signal voltage is given to amplifier unit through 0.1uf capacitor in order to filter the noise signal. The amplifier circuit is constructed with operational amplifier LM1458. The amplified output is in the form of AC signal the diode is used to rectify the negative signal. Piezo electric plate is the special type of sensor which is used to sense the mechanical vibration. Piezo electric plate converts the mechanical vibration to electrical signal. The converted electrical signal is in the range of small milli voltage signal.

Then the electrical signal voltage is given to amplifier unit through 0.1uf capacitor in order to filter the noise signal. The amplifier circuit is constructed with operational amplifier LM1458. The amplified output is in the form of AC signal the diode is used to rectify the negative signal. The rectified signal is given to comparator. The comparator circuit is constructed with LM1458 operational amplifier in which the signal is given to inverting input terminal. The reference voltage is given to non-inverting input terminal. It converts the input signal to $+12\text{V}$ to -12V square pulse.

The square pulse is given to base of BC 547 transistor whenever the positive side of square pulse is come the transistor conducts emitter and collector side is short circuited because the transistor is act as switch. The collector side is connected to trigger terminal of the 555 IC. When the transistor is conducted negative signal is given to trigger terminal because the emitter is connected to ground side. Now the 555 IC conducts and generates the square pulse. The frequency of the square pulse is depends upon the resistor and capacitor connected in between 7th (discharge) and 6th (threshold) terminal.

The square pulse is given to base of the Q2 transistor. The transistor is turn ON and turn OFF depends upon the square pulse. The Q2 transistor output is 0 to 5V pulse. Whenever the Piezo electric plate sense the vibration the Q2 transistor outputs the 0 to 5V pulse. This pulse is given to microcontroller or other related circuit to inform that vibration has been occurred.

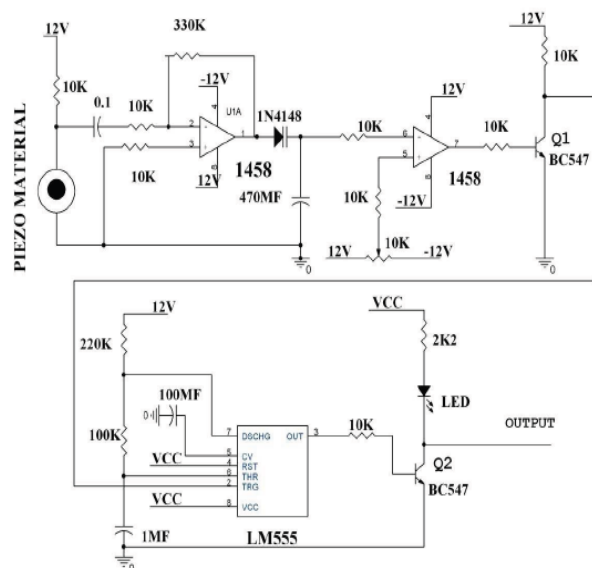

5. PROPOSED MODEL KIT

The proposed model has been constructed and the output of the proposed model has been checked by using the kit.

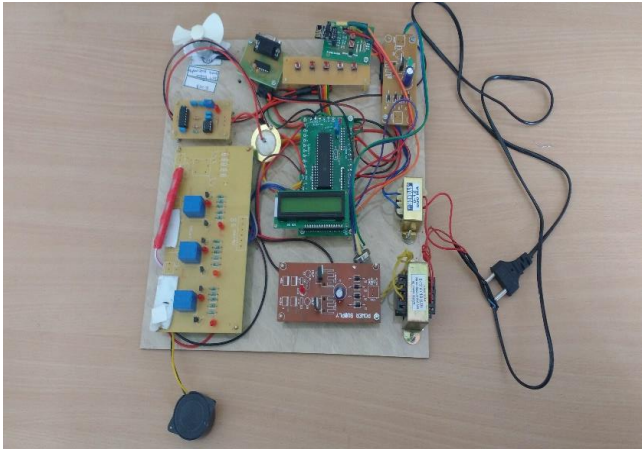

IOT Based Smart Home Design for Power and Security Management Kit

6. COMPONENTS USED IN PROPOSED MODEL

1. Relay.
2. Gas sensor.
3. LCD.
4. LDR.
5. Power supply.
6. Regulator.
7. Temperature sensor.
8. Vibration sensor.
9. IOT board.

7. CONCLUSION

The Internet of Things involves an increasing number of smart interconnected devices and sensors that are often non-intrusive, transparent and invisible. IoT has been bringing new set of technological changes in our daily lives, which in turn helping us to make our life simpler and more comfortable. Though IoT has abundant, the main observation of the paper is that IoT architecture will probably best be described by a reference model than a single architecture and that there will be many different as yet unknown applications/services that will connect to the IoT applies also to object resolution mechanisms. IoT applications rely on a communication infrastructure for exchanging information so it is important from a public policy point of view to ensure that IoT applications, which include healthcare, energy management, transportation, or any other innovative applications, will benefit from a fair access to this infrastructure.

REFERENCES

- [1] M. Song, S. Chang, and Y.-T. Lee, "A wake-up consumer device for enhanced emergency alert service in T-DMB systems," *IEEE Trans. Consumer Electron.*, vol. 61, no. 3, pp. 286-294, Aug. 2015.
- [2] A. Zanella, N. Bui, A. Castellani, L. Vangelista, and M. Zorzi, "Internet of things for smart cities," *IEEE Internet of Things Journal*, vol. 1, no. 1, pp. 22-32, Feb. 2014.

[3] L. Catarinucci, D. de Donno, L. Mainetti, L. Palano, L. Patrono, M. L. Stefanizzi, and L. Tarricone, "An IoT-aware architecture for smart healthcare systems," *IEEE Internet of Things Journal*, vol. 2, no. 6, pp. 515-526, Dec. 2015.

[4] Kosmatos, E.A., Tselikas, N.D. and Boucouvalas, A.C. (2011) Integrating RFIDs And Smart Objects into a Unified Internet of Things Architecture.

[5] Alberto M.C. Amazonas, Jose R.A. "A Novel Smart Home Application Using IOT".

[6] Aggarwal, R. and Lal Das, M. (2012) RFID Security in the Context of "Internet of Things" *First International Conference on Security of Internet of Things, Kerala*, 17- 19 August 2012, 51-56.

[7] *Honeywell Automation*: <https://homesecurity.honeywell.com>.

[8] Rintala, Mikko, Jussi Sormunen, Petri Kuisma, and Matti Rahkala. "Automation System Products and Research."(2014).

[9] Sandeep Patel, Punit Gupta, Mayank Kumar Goyal, "Low Cost Hardware Design of a Web Server for Home Automation Systems", *Conference on Advances in Communication and Control Systems (CAC2S)*, 2013.

[10] Golzar, M.G., Asan Pardazan Co., Tajozakerin, H.R., "A New Intelligent Remote Control System for Home Automation and Reduce Energy Consumption", *Mathematical/Analytical Modelling and Computer*.