

Zigbee Controlled Multi Functional Surveillance Spy Robot for Military Applications

R.Vedhapriyavadhana¹, E.Francy Irudaya Rani², Allwin Giftson³, S.Ajith Kumar⁴ and M.David Boon⁵

^{1,2}Assistant Professor, Department of Electronics and Communication Engineering, Francis Xavier Engineering College, Tirunelveli, India.

^{3,4,5}UG Students, Department of Electronics and Communication Engineering, Francis Xavier Engineering College, Tirunelveli, India.

Article Received: 30 December 2017

Article Accepted: 29 March 2018

Article Published: 31 May 2018

ABSTRACT

Robotics has been a staple of advanced manufacturing for over half a century. As robots and their peripheral equipment become more sophisticated, reliable and miniaturized, these systems are increasingly being utilized for military and law enforcement purposes. Mobile robotics plays an increasingly important role in military matters, from patrol to dealing with potential explosives. With suitable sensors and cameras to perform different missions, mobile robots are operated remotely for reconnaissance patrol and relay back video images to an operator. With the development of modern technology such as zigbee technology aims to exchange data wirelessly at a short distance using radio wave transmission comprising features to create ease, perception and controllability. This paper presents a modern approach for surveillance at remote and border areas using multifunctional robot based on zigbee technology used in defense and military applications. The robotic vehicle works both as a manually controlled vehicle using zigbee as communication medium. This robotic vehicle has ability to substitute the soldier at border areas to provide surveillance. The robotic vehicle works by manually controlling robotic vehicle by using zigbee as communication medium. And this multisensory robot is mainly used to detect bomb, defense soldier and it can act as a spy robot.

Keywords: Zigbee; metal detection Sensors; robotic vehicle.

1. INTRODUCTION

The robot is basically electro-mechanical machine or device that is controlled either by computer program or with electronic circuit to perform variety of physical tasks. As the terror is always remains India's first enemy so, the robots are going to use for saving human life. Countries like India are still facing and confronting with regular threats from terrors. Both Kashmir and Mumbai terror attacks have consummated that as far as possible the future of warfare will be handle by robot and unmanned machines to protect human life. Currently, the Indian Army has Daksh Military robot to combat in battle field. As the technology proliferate rapidly in automation field by incorporating Military Robots as Soldiers in war field to reduce grievance and demise in war fields [1].

2. EXISTING SYSTEM

Earlier surveillance robots sense only some physical quantities. Existing robots use expensive video camera for live video streaming for manual control. Currently existing robots have limited range of coverage. Still there is no robot that can point out target which guides a munitions or a missile accurately to the marked target. (for eg. if the laser is pointed towards the weakest portion or part of a tanker [2-22])

3. PROPOSED SYSTEM

This multifunctional robot has disseminated into modules which have their own functionality. Due to advancement in technology, these surveillance robots are advent to use in remote and defense areas. The power supply will be given to the following modules such as microcontroller, communication module, and sensing module and followed by the driving module [23-36]. This is the overall proposed system of the multifunctional robot. The main aim is to

make the robot to act as a defense soldier, bomb detector, also make the robot for the purpose surveillance in border areas.

3.1 BLOCK DIAGRAM OF PROPOSED SYSTEM

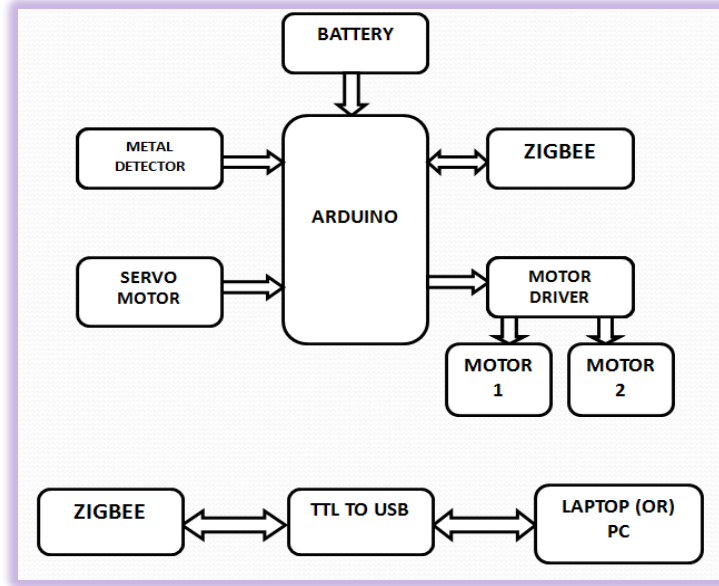

Fig: 1 Block Diagram of Proposed System

3.2 AUDRINO (ATMEGA 328)

The Atmega328 is a very popular microcontroller chip produced by Atmel. It is an 8-bit microcontroller that has 32K of flash memory, 1K of EEPROM, and 2K of internal SRAM. The Atmega328 is one of the microcontroller chips that are used with the popular Arduino Duemilanove boards. The Arduino Duemilanove board comes with either 1 of 2 microcontroller chips, the Atmega168 or the Atmega328. Of these 2, the Atmega328 is the upgraded, more advanced chip.

3.3 ZIGBEE

ZigBee is an open global standard for wireless technology designed to use low-power digital radio signals for personal area networks. ZigBee operates on the IEEE 802.15.4 specification and is used to create networks that require a low data transfer rate, energy efficiency and secure networking.

3.4 METAL DETECTOR

A metal detector is a device which responds to metal that may not be readily apparent. The simplest form of a metal detector consists of an oscillator producing an alternating current that passes through a coil producing an alternating magnetic field. If a piece of electrically conductive metal is close to the coil, eddy currents will be induced in the metal, and this produces a magnetic field of its own.

3.5 MOTOR DRIVER

A motor driver is an integrated circuit chip which is usually used to control motors in autonomous robots. Motor driver act as an interface between Arduino and the motors. The most commonly used motor driver IC's are from the L293 series such as L293D, L293NE, etc. These ICs are designed to control 2 DC motors simultaneously. The L293DD is assembled in a 20 lead surface mount which has 8 center pins connected together and used for heat sinking.

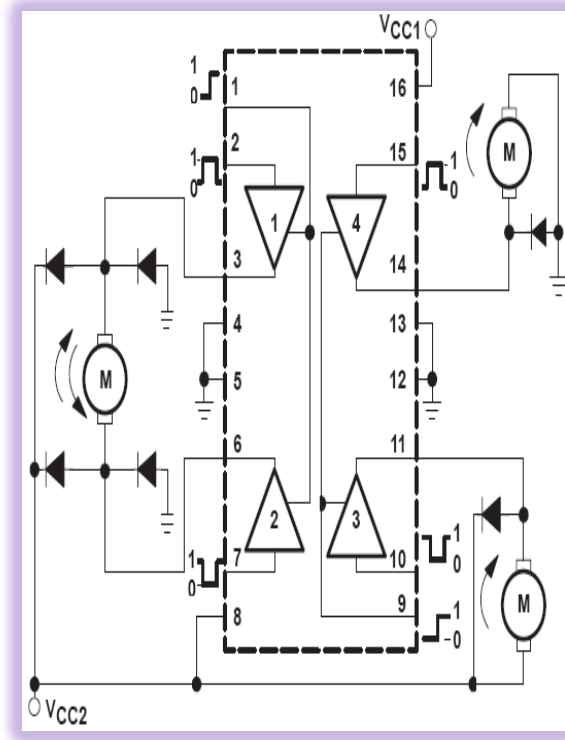

Fig: 2 Motor Driver Block Diagram

3.6 IC 7805 (VOLTAGE REGULATOR IC)

IC7805 is a voltage regulator integrated circuit. It is a member of 78xx series of fixed linear voltage regulator ICs. The voltage regulator IC maintains the output voltage at a constant value. The xx in 78xx indicates the fixed output voltage it is designed to provide. 7805 provides +5V regulated power supply. Capacitors of suitable values can be connected at input and output pins depending upon the respective voltage levels.

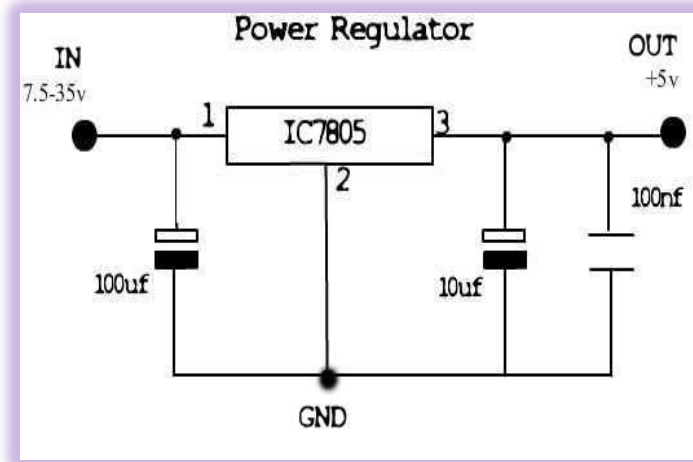

Fig: 3 Voltage Regulator IC Circuit

3.7 SERVO MOTOR

A servomotor is a rotary actuator or linear actuator that allows for precise control of angular or linear position, velocity and acceleration. Servomotors are used in applications such as robotics, CNC machinery or automated manufacturing.

4. RESULT AND DISCUSSION

This robotic vehicle with different sub modules can widely be used as surveillance robot for security purpose. Where human cannot footpace and user will be able to alert prior to intruder in his premises. It can also be used as a spy robot in case of border areas. By using the Metal detection sensor it can be used to detect bombs in its path etc. And its Laser gun can be used to attack enemies. It is user friendly. The captured photographs are given below,



Fig: 4 Robotic vehicle (Top View)



Fig: 5 Robotic vehicle (front view)

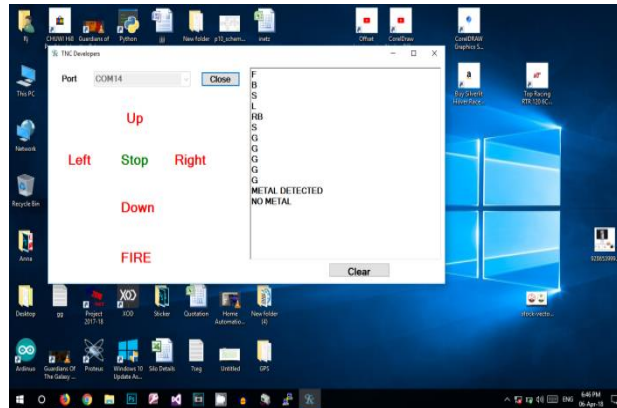

Fig: 6 Application that controls robotic vehicle running on PC

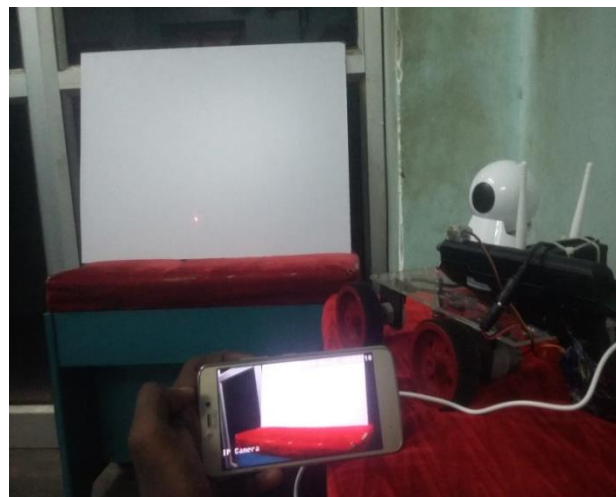

Fig: 7 Video live streaming by the robotic vehicle through smart phone

Following are the commands and their response, w-Forward, x-stop, A-left, S-Backward, D-right. While driving if any object is detected the robotic vehicle will check whether it is metal or not, if yes “Metal Detected” will be displayed on the screen. Finally, input G will allow the robot to fire.

5. CONCLUSION

It is very satisfying to implement this project and see it to function. The specifications are met and goals have been achieved. Thus, a wireless zigbee controlled robot was designed and it can be used for many applications as expected. The system developed multifunctional robot based on zigbee and by using arduino microcontroller. In order to strengthen the security and defence in any big country like ours we desperately require robotic system which will forearm our defence system. Hence in order to make this world a beautiful place to live we desperately require robot which will assist us in our endeavor. With advancement of this system, we will have a revolution in military and defense applications that changes society as once did by industry revolution.

ACKNOWLEDGEMENT

This work was supported in part by Department of Science & Technology (DST), FIST Program at Francis Xavier Engineering College, Tirunelveli, Tamilnadu, India.

REFERENCES

- [1] Monika Jain, Aditi, Ashwani Lohiya, Mohammad Fahad Khan: Wireless gesture control robot; International Journal of Advanced Research in Computer and Communication Engineering Vol. 1, Issue 10, December 2012
- [2] Muthukumaran. N and Ravi. R, 'Hardware Implementation of Architecture Techniques for Fast Efficient loss less Image Compression System', Wireless Personal Communications, Volume. 90, No. 3, pp. 1291-1315, October 2016, SPRINGER.
- [3] "Design of a multi-modal multi-controlled intelligent spybot" Anushka Gupta¹, Shailesh Tanwar, Vishvander Singh, M. Lavanya and V. K. Mittal IJaypee University of Information Technology,.
- [4] Wagnaghat, Solan, Himachal Pradesh, India Mukesh Patel School of Technology Management and Engineering, NMIMS, Mumbai, Maharashtra, India Army Institute of Technology, Pune, Maharashtra, India.
- [5] Muthukumaran. N and Ravi. R, 'The Performance Analysis of Fast Efficient Lossless Satellite Image Compression and Decompression for Wavelet Based Algorithm', Wireless Personal Communications, Volume. 81, No. 2, pp. 839-859, March 2015, SPRINGER.
- [6] R.C. Luo, and T.M. Chen, " Remote supervisory control of a sensor based mobile robot via Internet", Intr. Conf. on Intelligent Robots and Systems (IROS97), 1997. X. Xue, S.X. Yang, M.Q.-H Meng, "Remote Sensing and Teleoperation of A Mobile Robot Via the Internet", IEEE Intr Conf. on Information Acquisition, July 2005.
- [7] Gallagerher, James J. Low Intensity Conflict: A Guide for Tactics, Techniques, and Procedures. Mechanicsburg, PA: Stackpole, 1992.
- [8] Muthukumaran. N and Ravi. R, 'VLSI Implementations of Compressive Image Acquisition using Block Based Compression Algorithm', The International Arab Journal of Information Technology, vol. 12, no. 4, pp. 333-339, July 2015.
- [9] N. Yamasaki and Y. Anzai, "Active interface 10.www.Howstuffworks.com for understanding microphone concepts, rf Dougherty, Kevin "Remote Control Robots Get Trial Run In Bosnia," Stars and Stripes, 6 February 2000.
- [10] Muthukumaran. N and Ravi. R, 'Simulation Based VLSI Implementation of Fast Efficient Lossless Image Compression System using Simplified Adjusted Binary Code & Golomb Rice Code', World Academy of Science, Engineering and Technology, Volume. 8, No. 9, pp.1603-1606, 2014.
- [11] Anil Lamba, "Uses Of Cluster Computing Techniques To Perform Big Data Analytics For Smart Grid Automation System", International Journal for Technological Research in Engineering, Volume 1 Issue 7, pp.5804-5808, 2014.
- [12] Anil Lamba, "Uses Of Different Cyber Security Service To Prevent Attack On Smart Home Infrastructure", International Journal for Technological Research in Engineering, Volume 1, Issue 11, pp.5809-5813, 2014.
- [13] Anil Lamba, "A Role Of Data Mining Analysis To Identify Suspicious Activity Alert System", International Journal for Technological Research in Engineering, Volume 2 Issue 3, pp.5814-5825, 2014.
- [14] Anil Lamba, "To Classify Cyber-Security Threats In Automotive Doming Using Different Assessment Methodologies", International Journal for Technological Research in Engineering, Volume 3, Issue 3, pp.5831-5836, 2015.
- [15] Anil Lamba, "A Study Paper On Security Related Issue Before Adopting Cloud Computing Service Model", International Journal for Technological Research in Engineering, Volume 3, Issue 4, pp.5837-5840, 2015.
- [16] Anil Lamba, "Uses Of Artificial Intelligent Techniques To Build Accurate Models For Intrusion Detection System", International Journal for Technological Research in Engineering, Volume 2, Issue 12, pp.5826-5830, 2015.
- [17] Anil Lamba, "Mitigating Zero-Day Attacks In IOT Using A Strategic Framework", International Journal for Technological Research in Engineering, Volume 4, Issue 1, pp.5711-5714, 2016.
- [18] Ruban Kingston. M, Muthukumaran. and N, Ravi. R, 'A Novel Scheme of CMOS VCO Design with reduce number of Transistors using 180nm CAD Tool', International Journal of Applied Engineering Research, Volume. 10, No. 14, pp. 11934-11938, 2015.

- [19] Muthukumaran. N and Ravi. R, 'Design and analysis of VLSI based FELICS Algorithm for lossless Image Compression', International Journal of Advanced Research in Technology, Vol. 2, No. 3, pp. 115-119, March 2012.
- [20] Manoj Kumar. B and Muthukumaran. N, 'Design of Low power high Speed CASCADED Double Tail Comparator', International Journal of Advanced Research in Biology Engineering Science and Technology, Vol. 2, No. 4, pp.18-22, June 2016.
- [21] N. Muthukumaran, 'Analyzing Throughput of MANET with Reduced Packet Loss', Wireless Personal Communications, Vol. 97, No. 1, pp. 565-578, November 2017, SPRINGER.
- [22] P.Venkateswari, E.Jebitha Steffy, Dr. N. Muthukumaran, 'License Plate cognizance by Ocular Character Perception', International Research Journal of Engineering and Technology, Vol. 5, No. 2, pp. 536-542, February 2018.
- [23] N. Muthukumaran, Mrs R.Sonya, Dr.Rajashekhara and Chitra V, 'Computation of Optimum ATC Using Generator Participation Factor in Deregulated System', International Journal of Advanced Research Trends in Engineering and Technology, Vol. 4, No. 1, pp. 8-11, January 2017.
- [24] Ms. A. Aruna, Ms.Y.Bibisha Mol, Ms.G.Delcy, Dr. N. Muthukumaran, 'Arduino Powered Obstacles Avoidance for Visually Impaired Person', Asian Journal of Applied Science and Technology, Vol. 2, No. 2, pp. 101-106, April 2018.
- [25] Mrs. S. Murine Sharmili, Dr. N. Muthukumaran, 'Performance Analysis of Elevation & Building Contours Image using K-Mean Clustering with Mathematical Morphology and SVM', Asian Journal of Applied Science and Technology, Vol. 2, No. 2, pp. 80-85, April 2018.
- [26] Anil Lamba, "Identifying & Mitigating Cyber Security Threats In Vehicular Technologies", International Journal for Technological Research in Engineering, Volume 3, Issue 7, pp.5703-5706, 2016.
- [27] Anil Lamba, "S4: A Novel & Secure Method For Enforcing Privacy In Cloud Data Warehouses", International Journal for Technological Research in Engineering, Volume 3, Issue 8, pp.5707-5710, 2016.
- [28] Anil Lamba, "Cyber Attack Prevention Using VAPT Tools (Vulnerability Assessment & Penetration Testing)", Cikitusi Journal for Multidisciplinary Research, Volume 1, Issue 2, July - December, pp.64-71, 2014.
- [29] Anil Lamba, "A Through Analysis on Protecting Cyber Threats and Attacks on CPS Embedded Subsystems", International Journal of Current Engineering and Scientific Research (IJCESR), Volume-1, Issue-3, pp.48-55, 2014.
- [30] Anil Lamba, "Analysing Sanitization Technique of Reverse Proxy Framework for Enhancing Database-Security", International Journal of Information and Computing Science, Volume 1, Issue 1, pp.30-44, 2014.
- [31] Anil Lamba, "Enhancing Awareness of Cyber-Security and Cloud Computing using Principles of Game Theory", International Journal of Advanced in Management, Technology and Engineering Sciences, Volume III, Issue I, pp.71-82, 2013.
- [32] Anil Lamba, "Resolve Security Policies Conflicts Through Semantics Matching Alignment", International Journal of Scientific Research and Review, Volume 2, Issue 2, pp.43-58, 2013.
- [33] Anil Lamba, "A Detailed Analysis of Data Security in a cloud Environment", SURAJ PUNJ Journal for Multidisciplinary Research, Volume 3, Issue 2, pp.43-51, 2013.
- [34] Keziah. J, Muthukumaran. N, 'Design of K Band Transmitting Antenna for Harbor Surveillance Radar Application', International Journal on Applications in Electrical and Electronics Engineering, Vol. 2, No. 5, pp. 16-20, May 2016.
- [35] B.Renuka, B.Sivaranjani, A.Maha Lakshmi, Dr. N. Muthukumaran, 'Automatic Enemy Detecting Defense Robot by using Face Detection Technique', Asian Journal of Applied Science and Technology, Vol. 2, No. 2, pp. 495-501, April 2018.
- [36] Ms.Mary Varsha Peter, Ms.V.Priya, Ms.H.Petchammal, Dr. N. Muthukumaran, 'Finger Print Based Smart Voting System', Asian Journal of Applied Science and Technology, Vol. 2, No. 2, pp. 357-361, April 2018.
- [37] Muthukumaran. N and Ravi. R, 'Quad Tree Decomposition based Analysis of Compressed Image Data Communication for Lossy and Lossless using WSN', World Academy of Science, Engineering and Technology, Volume. 8, No. 9, pp. 1543-1549, 2014.