

Residential and Official Extension of IOT Enabled Building Automation System

R.Vedhapriyavadhana¹, E.Francy Irudaya Rani², Vignesh³, Vishnu Kumar⁴, Suvin⁵ and Murugan⁶

^{1,2}Assistant Professor, Department of Electronics and Communication Engineering, Francis Xavier Engineering College, Tirunelveli, India.

^{3,4,5,6}UG Students, Department of Electronics and Communication Engineering, Francis Xavier Engineering College, Tirunelveli, India.

Article Received: 30 December 2017

Article Accepted: 29 March 2018

Article Published: 31 May 2018

ABSTRACT

This project aims at achieving automation using the widely used mobile operating system ANDROID i.e. android operating system. The electrical and office appliances can be controlled using the android mobile phones and Internet of things (IoT) even if you are out of your house and you forgot to switch off the appliances. Many electrical and office appliances like light, fan, air conditioner etc., can be controlled using the android operating system. This proposed system is implemented in order to overcome the drawbacks of the previous methodologies. This can also be implemented at homes also. Office automation is the residential extension of building automation. Office automation may include centralized control of lighting, HVAC (heating, ventilation and air conditioning), appliances, to provide improved convenience, comfort, energy efficiency and security. Office automation for the elderly and disabled can provide increased quality of life for persons who might otherwise require caregivers or institutional care.

Keywords: IoT, Android, Automation.

1. INTRODUCTION

An embedded system is a computer system designed for specific control functions within a larger system; it can easily interface with real-time computing constraints. It is embedded as part of a complete device often including hardware and mechanical parts as well as software parts. By contrast, a general-purpose computer, it is designed to be flexible and to meet a wide range of end-user needs. Since the embedded system is dedicated to specific tasks, design engineers can optimize it to reduce the size and cost of the product and increase the reliability and performance. The main technology used here for wireless communication with the Office appliances and user is Internet of things. Internet is the wireless technology. It can be used to share a data between two ends such as transmitter as well receiver as well to transfer the commands between them. The IoT module will be connected with the micro-controller and the commands to the Office appliances from the user will be given through the android application.

2. IMPLEMENTATION SETUP

Components required,

1. Arduino node MCU
2. Accessible Wifi
3. Relays for connecting home appliances
4. Smart phone as a transmitter
5. Arduino genuino (Software).

2.1. ARDUINO NODE MCU

Node MCU is an open source IoT platform. It includes firmware which runs on the ESP8266Wi-Fi SoC from Express if Systems, and hardware which is based on the ESP-12 module. The term "Node MCU" by default refers

to the firmware rather than the dev kits. The firmware uses the Lua scripting language. It is based on the eLua project, and built on the Express if Non-OS SDK for ESP8266.

2.2. ACCESSIBLE WIFI

In order to provide the internet or cloud connection to the node MCU we need to provide an accessible WiFi or hot spot to the in-built wifi module of Arduino node MCU [1-12].

2.3. RELAYS

The 4-Channel Relay Driver Module makes it simple and convenient to drive loads such as 12V relays from simple 5V digital outputs of our Arduino compatible board or other micro-controller. We can use any of the control channels independently, so simply leave any unused channels disconnected.

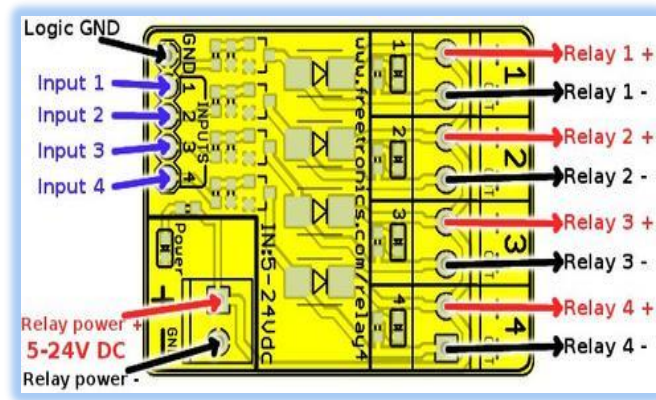

Figure.1 Channel relay

2.4. SMART PHONES AS TRANSMITTER

Using the android smart phones as a transmitter is a wise solution because it provides easy appearance and user friendly too. It provides a simplified process of controlling the office appliances [13-27]. But we cannot directly control the office appliances which are connected to the cloud network, for that purpose we need an Android application.

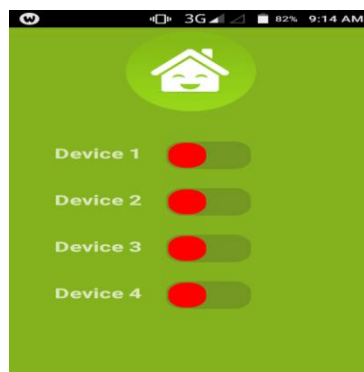

Figure 2 Android applications

2.5. ARDUINO GENUINO I.D.E

The Arduino Integrated Development Environment - or Arduino Software (IDE) - contains a text editor for writing code, a message area, a text console, a toolbar with buttons for common functions and a series of menus. It connects to the Arduino and Genuino hardware to upload programs and communicate with them [28-39].

3. SYSTEM MODEL

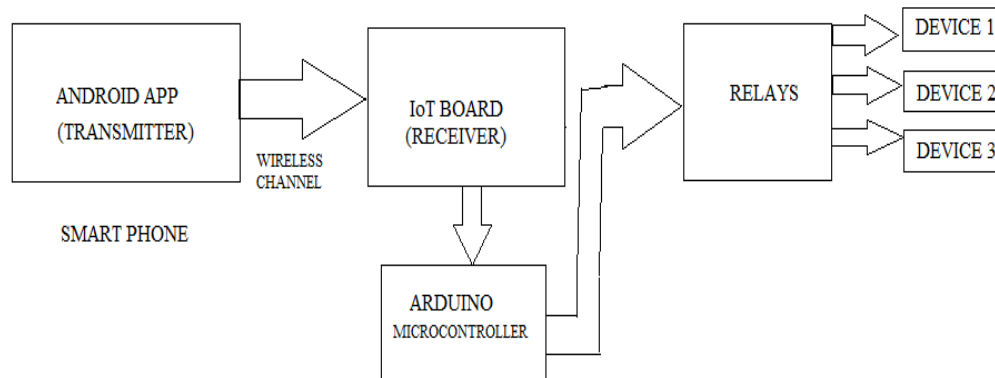

Figure 3 IoT block diagram

Here the android application can be used as a transmitter and the mobile phone and arduino micro controller connected wirelessly. IoT board receives the signal from the android app and gives that to the microcontroller. Microcontroller gives that signal to ON the relays.

3.1. FEATURES

1. Uses 3G modem or Quad band GSM cellular modem.
2. Can be used as an IoT gateway.
3. Two modes (a) Alarm reporting mode (b) Continuous monitoring mode.
4. Battery low reporting through SMS and/or GPRS.
5. Output relays can be controlled through SMS and/or GPRS. Latching relays are used to preserve state in case of power failures.
6. Buzzer on and off control remotely through SMS and/or GPRS.
7. Analog inputs alarms are sent when condition is satisfied (voltage exceeds certain threshold or goes below certain threshold including hysteresis).
8. All inputs (digital + analog) & output status periodic reporting configurable for every x seconds over SMS and/or GPRS.
9. Dual SIM capability, the 2nd SIM will be used as backup in case there is no connectivity using the 1st SIM.
10. Has an I2C bus connector to optionally connect to an external temperature/humidity sensor and monitor the same.

11. Optional RS232/RS485 interface for monitoring and reporting external RS232/RS485 based sensors & equipment like Energy meters, Tilt sensors, accelerometers, Fuel or liquid level sensors, Weight/Pressure sensors, Vibration sensors etc.
12. All configurations can be done through SMS. Optionally USB can be used for configuring the device also.

4. IMPLEMENTATION SETUP



Figure 4 IoT implementation setup.

Here we are having two modes of operations such as manual as well as automatic mode of operation. During the manual mode we can directly ON and OFF the off the appliances, similar to that during the automatic mode of operation we can control the office appliances from anywhere. The outputs are,



1. Device ON



2. Devices ON



3. Devices ON



4. Devices ON

Figure 5 Outputs

4.1. APPLICATIONS

1. IoT Gateway / Machine to machine (M2M) hardware
2. Reports the states of analog/digital inputs & also RS-485 modbus slaves over internet or SMS.
3. GPRS/3G/SMS based Remote Alarm Monitoring & Reporting.
4. Energy/Power monitoring.
5. Remote Temperature/Humidity monitoring.
6. Remote Water & Liquid level monitoring & control.

5. CONCLUSION AND FUTURE ENHANCEMENT

It is very satisfying to implement this project and see its function. The specification is met and goals have been achieved. The system developed automation based on internet of things, is an alternative that can be used to help people with various worst technologies. Likewise with this set of solution the aim is to improve the quality of life of people, not just monitoring the devices, but also to enable direct them to improve their efficiency.

The context model developed for the system prove to be the efficient when making inferences related to the context, such as recommendations for taking measures through sensors as well as the workout routines tips to improve the power saving capability as well improved performances .In this paper we try to compare the existing methods for ensuring the automation methodologies.

ACKNOWLEDGEMENT

This work was supported in part by Department of Science & Technology (DST), FIST Program at Francis Xavier Engineering College, Tirunelveli, Tamilnadu, India.

REFERENCES

- [1] M. N. N. A. Asghar, M.H., "Principle application and vision in internet of things (iot)," in Communication Technologies (GCCT), 2015 Global Conference on, may 2015.
- [2] Muthukumaran. N and Ravi. R, 'Hardware Implementation of Architecture Techniques for Fast Efficient loss less Image Compression System', Wireless Personal Communications, Volume. 90, No. 3, pp. 1291-1315, October 2016, SPRINGER.
- [3] R. . C. Y. . O. K. Withanage, C., "A comparison of the popular home automation technologies," pp. 1 – 11, may 2014.
- [4] Muthukumaran. N and Ravi. R, 'The Performance Analysis of Fast Efficient Lossless Satellite Image Compression and Decompression for Wavelet Based Algorithm', Wireless Personal Communications, Volume. 81, No. 2, pp. 839-859, March 2015, SPRINGER.
- [5] White Paper: "Internet of Things Strategic Research Roadmap", Antoine de Saint-Exupery, 15 sep 2009.
- [6] Muthukumaran. N and Ravi. R, 'VLSI Implementations of Compressive Image Acquisition using Block Based Compression Algorithm', The International Arab Journal of Information Technology, vol. 12, no. 4, pp. 333-339, July 2015.
- [7] Anil Lamba, "Uses Of Cluster Computing Techniques To Perform Big Data Analytics For Smart Grid Automation System", International Journal for Technological Research in Engineering, Volume 1 Issue 7, pp.5804-5808, 2014.
- [8] Anil Lamba, "Uses Of Different Cyber Security Service To Prevent Attack On Smart Home Infrastructure", International Journal for Technological Research in Engineering, Volume 1, Issue 11, pp.5809-5813, 2014.

- [9] Anil Lamba, "A Role Of Data Mining Analysis To Identify Suspicious Activity Alert System", International Journal for Technological Research in Engineering, Volume 2 Issue 3, pp.5814-5825, 2014.
- [10] Anil Lamba, "To Classify Cyber-Security Threats In Automotive Domain Using Different Assessment Methodologies", International Journal for Technological Research in Engineering, Volume 3, Issue 3, pp.5831-5836, 2015.
- [11] Anil Lamba, "A Study Paper On Security Related Issue Before Adopting Cloud Computing Service Model", International Journal for Technological Research in Engineering, Volume 3, Issue 4, pp.5837-5840, 2015.
- [12] Anil Lamba, "Uses Of Artificial Intelligent Techniques To Build Accurate Models For Intrusion Detection System", International Journal for Technological Research in Engineering, Volume 2, Issue 12, pp.5826-5830, 2015.
- [13] Anil Lamba, "Mitigating Zero-Day Attacks In IOT Using A Strategic Framework", International Journal for Technological Research in Engineering, Volume 4, Issue 1, pp.5711-5714, 2016.
- [14] Nicholas D., Darrell B., Somsak S., "Home Automation using Cloud Network and Mobile Devices," IEEE Southeastcon 2012, Proceedings of IEEE.
- [15] Muthukumaran. N and Ravi. R, 'Simulation Based VLSI Implementation of Fast Efficient Lossless Image Compression System using Simplified Adjusted Binary Code & Golomb Rice Code', World Academy of Science, Engineering and Technology, Volume. 8, No. 9, pp.1603-1606, 2014.
- [16] Ruban Kingston. M, Muthukumaran. and N, Ravi. R, 'A Novel Scheme of CMOS VCO Design with reduce number of Transistors using 180nm CAD Tool', International Journal of Applied Engineering Research, Volume. 10, No. 14, pp. 11934-11938, 2015.
- [17] Chan, M., Campo, E., Esteve, D., Fourniols, J.Y., "Smart homes-current features and future perspectives," Maturitas, vol. 64, issue 2, pp. 90-97, 2009.
- [18] Muthukumaran. N and Ravi. R, 'Design and analysis of VLSI based FELICS Algorithm for lossless Image Compression', International Journal of Advanced Research in Technology, Vol. 2, No. 3, pp. 115-119, March 2012.
- [19] Manoj Kumar. B and Muthukumaran. N, 'Design of Low power high Speed CASCADED Double Tail Comparator', International Journal of Advanced Research in Biology Engineering Science and Technology, Vol. 2, No. 4, pp.18-22, June 2016.
- [20] N. Muthukumaran, 'Analyzing Throughput of MANET with Reduced Packet Loss', Wireless Personal Communications, Vol. 97, No. 1, pp. 565-578, November 2017, SPRINGER.
- [21] P.Venkateswari, E.Jebitha Steffy, Dr. N. Muthukumaran, 'License Plate cognizance by Ocular Character Perception', International Research Journal of Engineering and Technology, Vol. 5, No. 2, pp. 536-542, February 2018.
- [22] N. Muthukumaran, Mrs R.Sonya, Dr.Rajashekhara and Chitra V, 'Computation of Optimum ATC Using Generator Participation Factor in Deregulated System', International Journal of Advanced Research Trends in Engineering and Technology, Vol. 4, No. 1, pp. 8-11, January 2017.
- [23] Ms. A. Aruna, Ms.Y.Bibisha Mol, Ms.G.Delcy, Dr. N. Muthukumaran, 'Arduino Powered Obstacles Avoidance for Visually Impaired Person', Asian Journal of Applied Science and Technology, Vol. 2, No. 2, pp. 101-106, April 2018.
- [24] Mrs. S. Murine Sharmili, Dr. N. Muthukumaran, 'Performance Analysis of Elevation & Building Contours Image using K-Mean Clustering with Mathematical Morphology and SVM', Asian Journal of Applied Science and Technology, Vol. 2, No. 2, pp. 80-85, April 2018.
- [25] Keziah. J, Muthukumaran. N, 'Design of K Band Transmitting Antenna for Harbor Surveillance Radar Application', International Journal on Applications in Electrical and Electronics Engineering, Vol. 2, No. 5, pp. 16-20, May 2016.
- [26] Anil Lamba, "Identifying & Mitigating Cyber Security Threats In Vehicular Technologies", International Journal for Technological Research in Engineering, Volume 3, Issue 7, pp.5703-5706, 2016.
- [27] Anil Lamba, "S4: A Novel & Secure Method For Enforcing Privacy In Cloud Data Warehouses", International Journal for Technological Research in Engineering, Volume 3, Issue 8, pp.5707-5710, 2016.
- [28] Anil Lamba, "Cyber Attack Prevention Using VAPT Tools (Vulnerability Assessment & Penetration Testing)", Cikitusi Journal for Multidisciplinary Research, Volume 1, Issue 2, July - December, pp.64-71, 2014.
- [29] Anil Lamba, "A Through Analysis on Protecting Cyber Threats and Attacks on CPS Embedded Subsystems", International Journal of Current Engineering and Scientific Research (IJCESR), Volume-1, Issue-3, pp.48-55, 2014.

- [30] Anil Lamba, “Analysing Sanitization Technique of Reverse Proxy Framework for Enhancing Database-Security”, International Journal of Information and Computing Science, Volume 1, Issue 1, pp.30-44, 2014.
- [31] Anil Lamba, “Enhancing Awareness of Cyber-Security and Cloud Computing using Principles of Game Theory”, International Journal of Advanced in Management, Technology and Engineering Sciences, Volume III, Issue I, pp.71-82, 2013.
- [32] Anil Lamba, “Resolve Security Policies Conflicts Through Semantics Matching Alignment”, International Journal of Scientific Research and Review, Volume 2, Issue 2, pp.43-58, 2013.
- [33] Anil Lamba, “A Detailed Analysis of Data Security in a cloud Environment”, SURAJ PUNJ Journal for Multidisciplinary Research, Volume 3, Issue 2, pp.43-51, 2013.
- [34] B.Renuka, B.Sivaranjani, A.Maha Lakshmi, Dr. N. Muthukumar, 'Automatic Enemy Detecting Defense Robot by using Face Detection Technique', Asian Journal of Applied Science and Technology, Vol. 2, No. 2, pp. 495-501, April 2018.
- [35] Ms.Mary Varsha Peter, Ms.V.Priya, Ms.H.Petchammal, Dr. N. Muthukumar, 'Finger Print Based Smart Voting System', Asian Journal of Applied Science and Technology, Vol. 2, No. 2, pp. 357-361, April 2018.
- [36] Muthukumar. N and Ravi. R, 'Quad Tree Decomposition based Analysis of Compressed Image Data Communication for Lossy and Lossless using WSN', World Academy of Science, Engineering and Technology, Volume. 8, No. 9, pp. 1543-1549, 2014.
- [37] Sirsath N. S, Dhole P. S, Mohire N. P, Naik S. C & Ratnaparkhi N.S Department of Computer Engineering, 44, Vidyanagari, Parvati, Pune-411009, India University of Pune, “Home Automation using Cloud Network and Mobile Devices” .
- [38] Deepali Javale, Mohd. Mohsin, Shreerang Nandanwar “Home Automation and Security System Using Android ADK” in International Journal of Electronics Communication and Computer Technology (IJECCCT) Volume 3 Issue 2 (March 2013).
- [39] S.D.T. Kelly, N.K. Suryadevara, S.C. Mukhopadhyay, “Towards the Implementation of IoT for Environmental Condition Monitoring in Homes”, IEEE, Vol. 13, pp. 3846-3853, 2013.